



Selection: Open Screw Compressors OS

Input Values

Compressor model	OSN7451-K	Operating mode	Economiser
Refrigerant	R404A	Speed	2900 /min
Reference temperature	Dew point temp.	Useful superheat	100%
Liq. subc. (in condenser)	0 K	Additional cooling	Automatic
Auto. subcooling	Auto	Max. discharge gas temp.	80,0 °C
Suct. gas superheat	10,00 K	Cooling capacity	100 %

Result

Q [W]	Cooling capacity	Qac [kW]	Additional cooling
P [kW]	Power input	tcu [°C]	Liquid temp.
COP [-]	COP/EER	pm [bar(a)]	ECO pressure
mLP [kg/h]	Mass flow LP	Qsc [kW]	sub cooler capacity (ECO)
mHP [kg/h]	Mass flow HP		

tc	to	-15°C	-20°C	-25°C	-30°C	-35°C	-40°C	-45°C	-50°C
30°C	Q [W]	135124	113050	93678	76720	61916	49032	37856	28200
	P [kW]	41,1	39,1	37,7	36,7	35,8	34,7	33,3	31,3
	COP [-]	3,29	2,89	2,48	2,09	1,73	1,41	1,14	0,90
	mLP [kg/h]	3321	2745	2244	1810	1437	1118	847	618
	mHP [kg/h]	3897	3327	2814	2354	1941	1572	1243	949
	Qac [kW]	--	--	--	--	3,65	6,22	8,81	11,12
	tcu [°C]	14,14	10,82	7,26	3,46	-0,60	-4,93	-9,53	-14,43
	pm [bar(a)]	6,88	6,20	5,54	4,88	4,25	3,65	3,08	2,56
	Qsc [kW]	21,4	21,4	20,6	19,35	17,62	15,55	13,25	10,79
	40°C	Q [W]	124745	104437	86603	70967	57290	45359	34990
P [kW]		49,3	47,9	46,8	45,9	45,0	43,8	42,3	
COP [-]		2,53	2,18	1,85	1,55	1,27	1,04	0,83	
mLP [kg/h]		3258	2686	2189	1759	1391	1076	810	
mHP [kg/h]		4085	3494	2962	2483	2052	1665	1319	
Qac [kW]		--	4,25	6,12	8,39	10,98	13,73	16,48	
tcu [°C]		20,0	16,51	12,73	8,65	4,25	-0,46	-5,51	
pm [bar(a)]		8,20	7,39	6,58	5,79	5,01	4,27	3,58	
Qsc [kW]		27,8	26,8	25,2	23,1	20,7	17,96	15,08	
50°C		Q [W]	110425	92549	76791	62907	50691	39963	30570
	P [kW]	61,0	59,9	58,7	57,4	56,2	54,9	53,6	
	COP [-]	1,81	1,55	1,31	1,10	0,90	0,73	0,57	
	mLP [kg/h]	3113	2555	2072	1654	1297	992	735	
	mHP [kg/h]	4217	3616	3072	2579	2133	1730	1364	
	Qac [kW]	12,33	14,11	16,18	18,53	21,2	24,5	28,6	
	tcu [°C]	26,7	23,0	18,88	14,44	9,61	4,38	-1,28	
	pm [bar(a)]	9,93	8,94	7,93	6,94	5,97	5,04	4,15	
	Qsc [kW]	32,9	31,0	28,7	25,9	22,8	19,49	16,05	

-- No calculation possible (see message in single point selection)

*According to EN12900 (10K suction gas superheat, liquid subcooling in Economiser with 5K temperature difference)

Application Limits ECO OSN7451

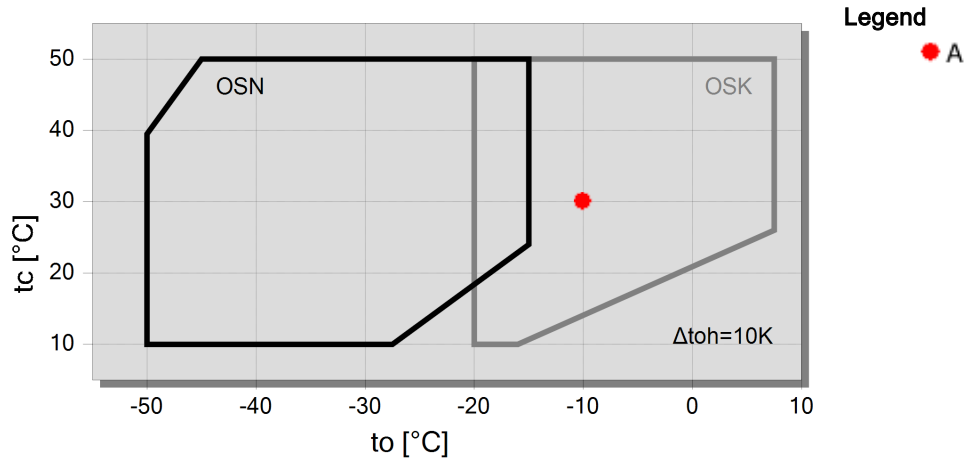



Technical Data: OSN7451-K

Dimensions and Connections

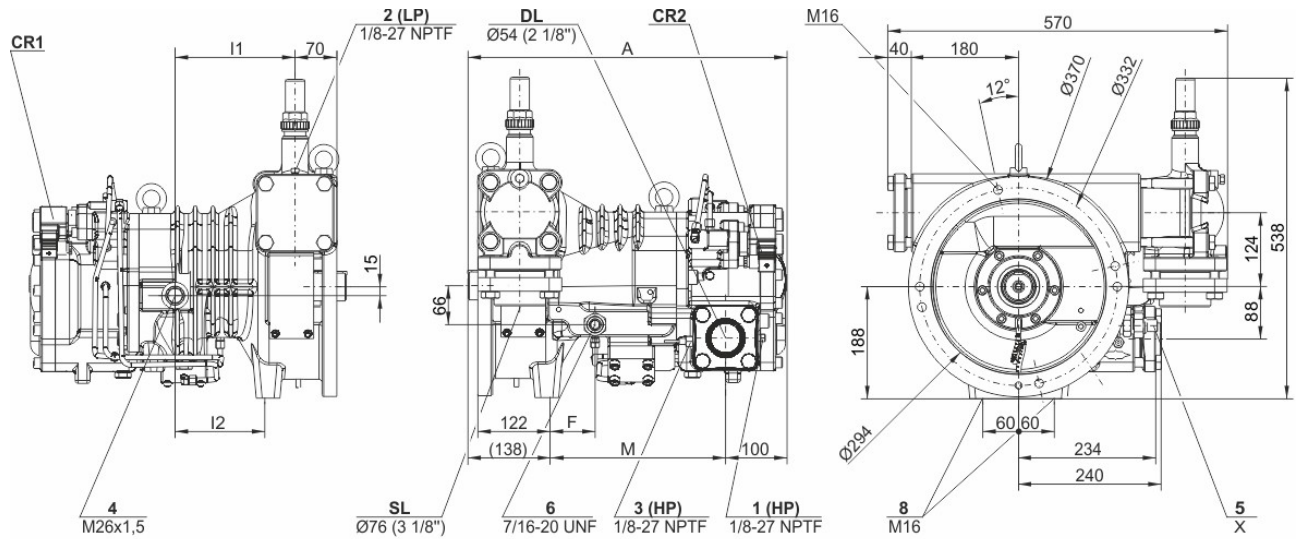

	A	F	I1	I2	M	X
	mm	mm	mm	mm	mm	
OS.7441*; OS.7451; OS.7461	533	76	202	152	295	Ø16
OS.7471	555	98	224	174	317	Ø16
OS.A7452; OS.A7462	533	76	202	152	295	DN15
OS.A7472	555	98	224	174	317	DN15

* OS.7441 hat nur ein Magnetventil (CR1) zur Steuerung der Leistungsregelung

* OS.7441 has only one solenoid valve (CR1) to control the capacity control



Technical Data

Technical Data

Displacement (2900 RPM 50 Hz)	192 m ³ /h
Displacement (3500 RPM 60 Hz)	232 m ³ /h
Allowed speed range	1450 .. 4000 min ⁻¹
Sens of rotation (compressor)	links / counter-clockwise
Weight	176 kg
Max. pressure (LP/HP)	19 / 28 bar
Connection suction line	76 mm - 3 1/8"
Connection suction line (NH3)	DN 80
Connection discharge line	54 mm - 2 1/8"
Connection discharge line (NH3)	DN 50
Oil type R22	B150SH, B100 (Option)
Oil type R134a/R404A/R507A/R407A/R407F	BSE170 (Option)

Extent of delivery (Standard)

Suction shut-off valve	Standard
Pressure relief valve	Standard
Check valve	Standard
Oil injection kit	Standard
Built in oil filter	Standard
discharge gas temperature monitoring	SE-B3
Discharge gas temperature sensor	Standard
Start unloading	Standard
Capacity control	100-75-50% (Standard)
Sight glass	Standard
Protective charge	Standard

Available Options

Oil flow control	Option
Discharge shut-off valve	Option
ECO connection with shut-off valve	Option
Adapter/shut-off valve for ECO	22 mm - 7/8" (Option)
Coupling housing	Option



Open Screw Compressors OS

OSK = Application for air-conditioning and medium temperature cooling.

OSN = Application for low temperature cooling.

OSH = Application for air-conditioning and heat pumps.

Notes regarding application limits (see "T.Data - Limits")

* Ranges are valid for standart operation and at full-load conditions.

* With high pressure conditions, part-laod operation is partly limited (see application limits in applications manual SH-500/SH-510).

* With Economizer operation the maximum admissible evaporation temperature is shifted by 10K downward (otherwise there is a danger of excessive compression and overlaod of the motor because of a higher mass flow). At pull-down conditions from higher evaporation temperatures, the ECO injection must remain closed until the evaporation temperature is below the maximum admissible value and a stable operation is achieved (e.g. control of the ECO solenoid valve by means of a low pressure cut-out). The use of the ECO-System with higher evaporation temperatures requires individual consultation with Bitzer.

OS53..OS74

* Capacity control with ECO operation at the same time is limited to one single regulating step (CR 75%). At CR 50% the ECO injection should be closed.

* Combined operation (ECO + CR 50%) is possible under certain conditions, control and system design, however, require individual consultation with Bitzer.

Motor Selection

The required driving motor is selected for starting conditions at direct start as well as at star-delta-start with start unloading (50% capcaity regulation). The starting conditions refer to the following defined operation points resp. to the maximum application limit of the compressor. Should the evaporation- or the condensing temperature of the plant be higher at the start, an individual motor selection is necessary.

Evaporation temperature for motor selection				
	HH	H	M	L
R134a	+20 °C	+12,5 °C	-5 °C	
R404A / R507A		+7,5 °C	-5 °C	-15 °C
R22		+12,5 °C	-5 °C	-10 °C
R407C		+12,5 °C	-5 °C	
NH ₃	+25 °C	+12,5 °C	-5 °C	-10 °C

The stated motor data refer to IEC motors at which the pull-up torque should not fall below 90% of the max. torque. In addition the following starting torque (referring to direct start) must be reached:

* open screw compressors 120%

Should the motor not fulfil these criteria, an individual selection is also necessary.

Lubricants and additional cooling for NH3 applications

	Type	Viscosity	Discharge gas (°C)	Oil injection (°C)
Reniso KM32	MO	32	ca. 60 .. max. 100	max. 50
Reniso KS46	MO	46	ca. 60 .. max. 80 (100 [1])	max. 60
Reniso KC68	MO	68	ca. 60 .. max. 80 (100 [1])	max. 60
Reflo 68A	MO (HT)	58	ca. 60 .. max. 80 (100 [1])	max. 60
SHC226E	PAO	68	ca. 60 .. max. 80 (100 [1])	max. 60

[1] 100 °C only after consultation with BITZER

Further information on the selection of lubricants can be found in the Application Manuals SH-500 and SH-510.

**Legend of connection positions according to "Dimensions":**

- 1 High pressure connection (HP)
Connection for high pressure switch (HP)
- 1a Additional high pressure connection (HP)
Not suitable for pressure switch or pressure transmitter!
- 1b Connection for high pressure transmitter (HP)
- 2 Low pressure connection (LP)
Connection for low pressure switch
- 2a Additional low pressure connection (LP)
- 2b Connection for low pressure transmitter (LP)
- 2c Low pressure connection for the minimum pressure differential control valve
- 3 Connection for discharge gas temperature sensor (HP)
- 4 Connection for economiser (ECO)
 HS.85: ECO valve with connection line (option)
 OS.85, OS.95, OS.105, HS.95: ECO valve (option)
- 5 Connection/valve for oil injection
- 6 Oil pressure connection
- 7 Oil drain (compressor or motor housing)
- 7a Oil drain (suction gas filter)
- 7b Oil drain from shaft seal (maintenance connection)
- 7c Oil drain hose (shaft seal)
- 8 Threaded bore for foot fastening
- 9 Threaded bore for pipe fixture (ECO and LI lines)
- 10 Maintenance connection for oil filter
- 11 Oil drain (oil filter)
- 13 Oil filter monitoring
- 14 Oil flow switch
- 15 Earth screw for housing
- 16 Pressure blow-off (oil filter chamber)
- 17 Maintenance connection for shaft seal
- 18 Liquid injection (LI)
- 19 Compressor module
- 20 Slider position indicator
- 21 Oil level switch
- 22 Oil pressure transmitter
- 23 Connection for oil and gas return (for systems with flooded evaporator adaptor optional)
- 24 Access to oil circulation restrictor
- 25 Oil inlet for shaft seal cooling
- 26 Oil outlet for shaft seal cooling
- 27 Temperature sensor in the shaft seal
- 28 Vibration sensor connection
- SL Suction gas line
- DL Discharge gas line

Dimensions can show tolerances according to EN ISO 13920-B.